

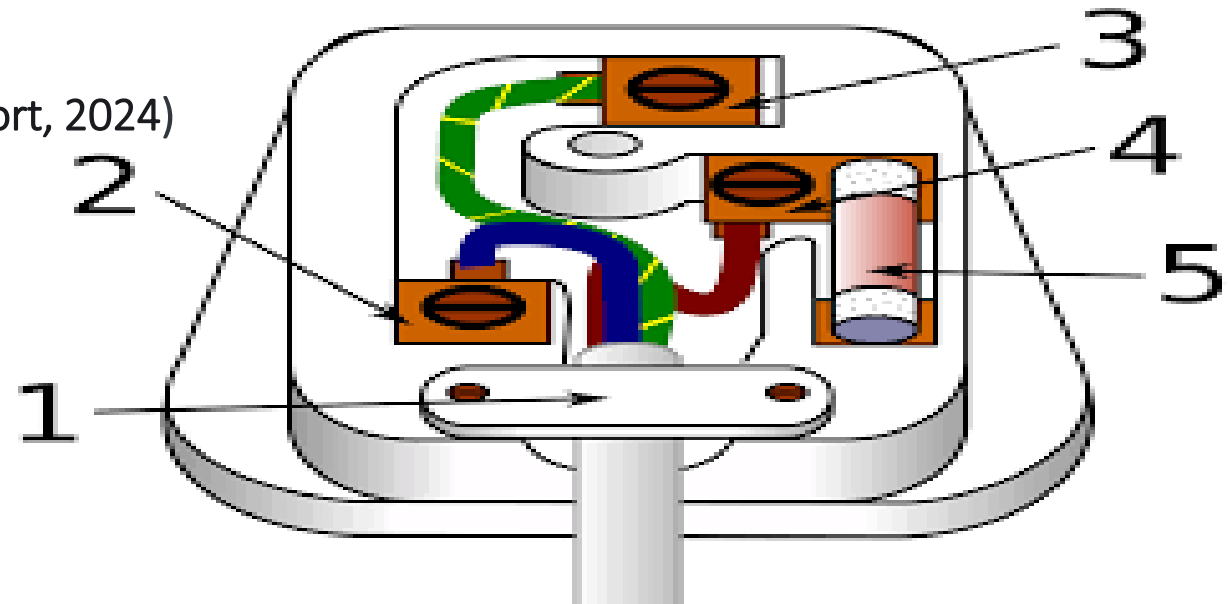

**PROGRAMME: ICP
CENTRE: POINT FORTIN GVC
COURSE: ELECTRICAL
INSTALLATION LEVEL # 1
INSTRUCTOR: MASLYN VERNE
MENDEZ**



(Vandervort, 2024)



Attach flexible cables, outlets & plugs to install an extension cord.

VIDEO ON FLEXIBLE CORD AND PLUG CONNECTION

<https://www.youtube.com/watch?v=Bpo7M3B06gY>

<https://www.youtube.com/watch?v=ADtQPvqwOvM>

<https://www.youtube.com/watch?v=fm54EShv27I>

<https://www.youtube.com/watch?v=xex8cPv8CtA>

LESSON OBJECTIVES

At the end of this lesson, the audience will be able to gain knowledge and understanding of: how to attach flexible cables, outlets & plugs to electrical machinery appliances and fixtures.

On completion of this unit, the trainees will be able to:

- Identify what is a plug.
- Identify what is a receptacle outlet.
- Select the different types of plugs.
- Select the different types of outlets.

LESSON OBJECTIVES

At the end of this lesson, the audience will be able to gain knowledge and understanding of: how to attach flexible cables, outlets & plugs to electrical machinery appliances and fixtures.

On completion of this unit, the trainees will be able to:

- Identify plug installation for electrical machinery.
- Identify flexible cord installation for electrical machinery.
- Install the plug circuit.
- Install the outlet circuit.

What is a plug ?

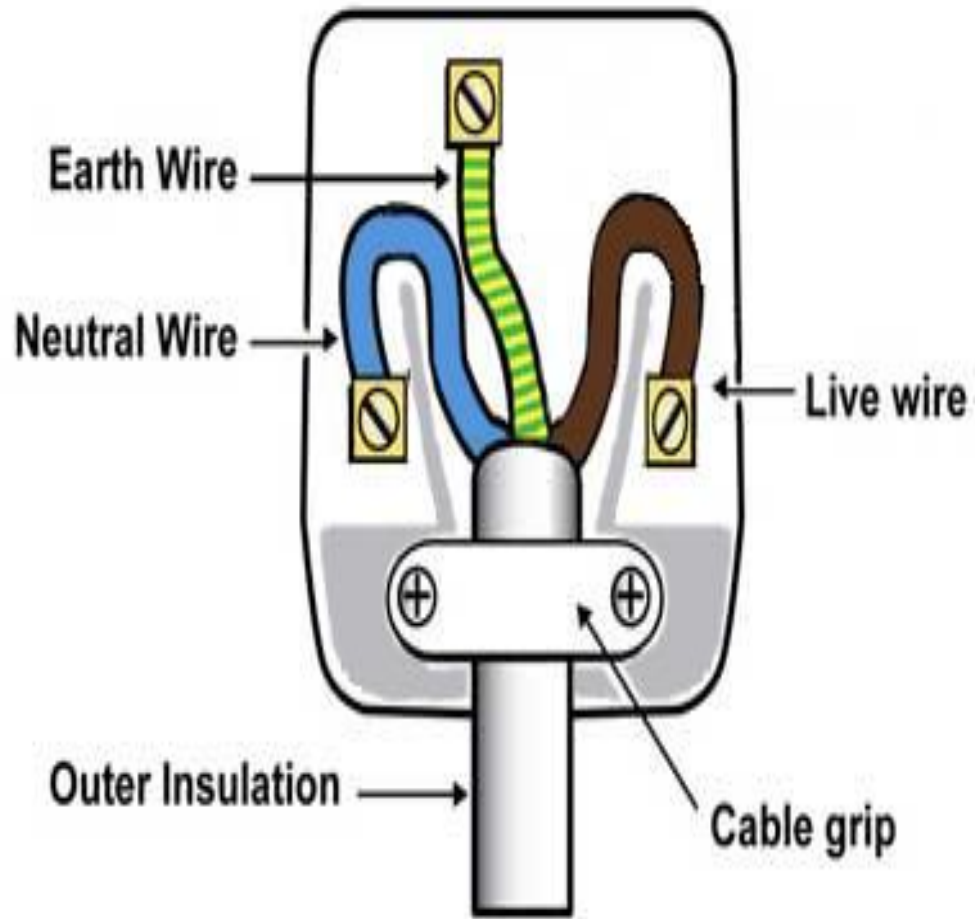

A plug is a device intended for connection to a flexible cord or flexible cable which can be engaged manually with a receptacle outlet, connector or adaptor and which has current-carrying contact pins which may be exposed when not engaged.

(Vandervort, 2024)

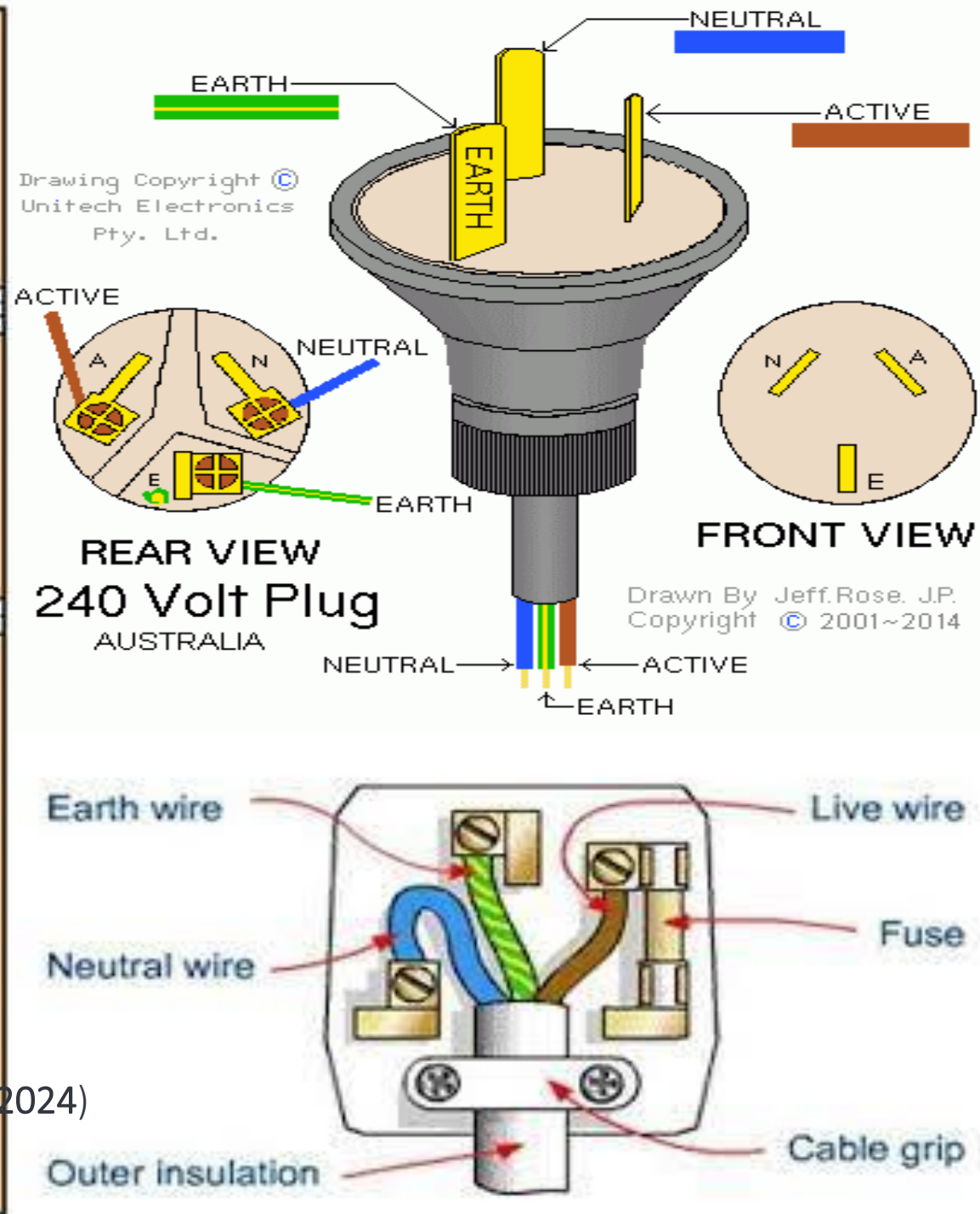
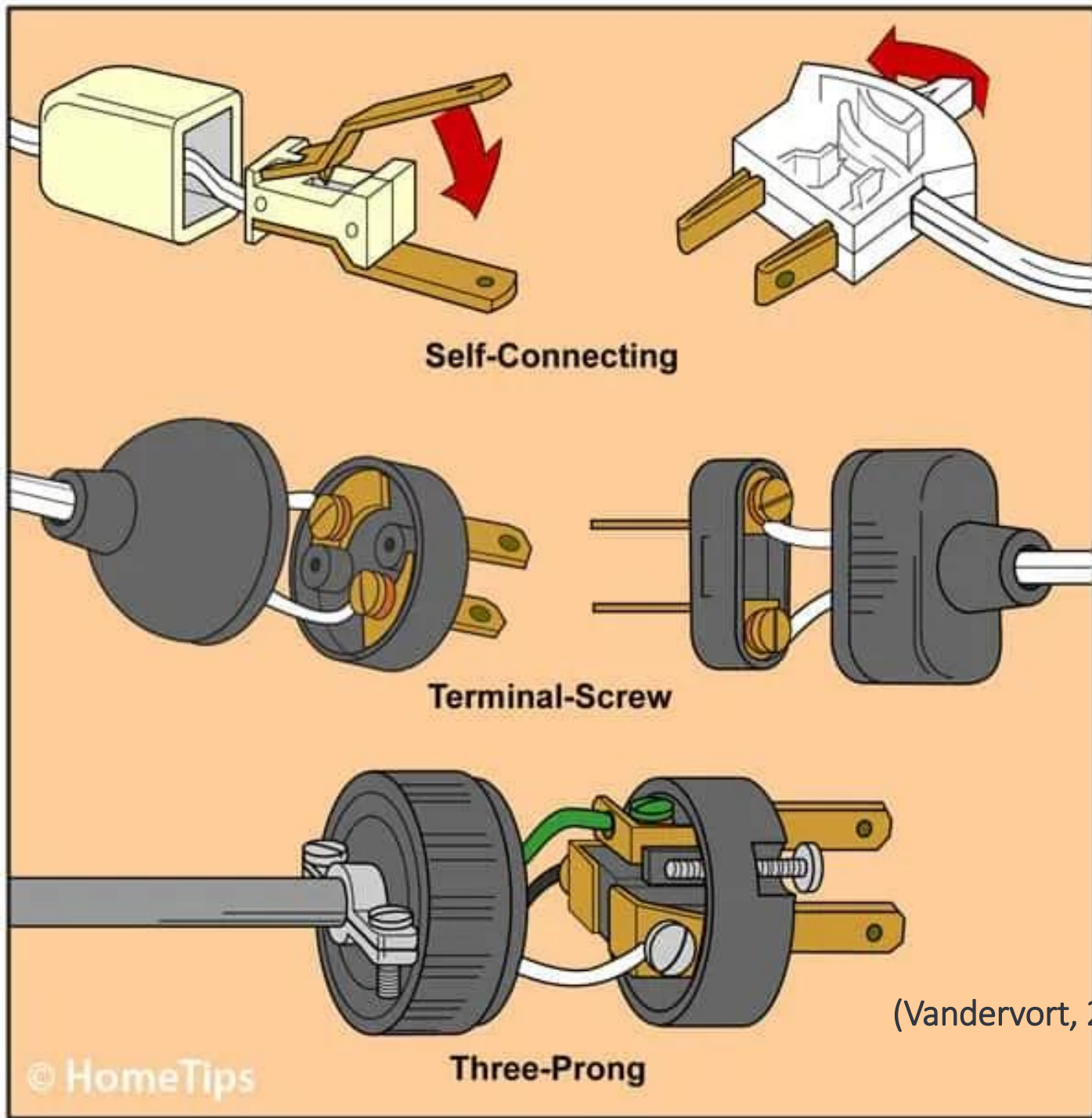

THE MATERIALS REQUIRED TO WIRE A PLUG

AMOUNT

- 1
- 4 YARDS
- 1
- 1
- 2 ½
- 1
- 1

DESCRIPTION

- 3 PIN 15 AMP 115V PLUG
- 3*2.5MM RHINO CABLE
- 2*4 PVC BOX
- 15 AMP 115V RECEPTACLE OUTLET
- COMPRESSION GLANDS PVC
- RECEPTACLE OUTLET COVER
- ROLL GREY ELECTRICAL TAPE

PICTURES OF THE REQUIRED MATERIALS

RHINO CABLE 3*2.5MM



15A RECEPTACLE
OUTLET AND COVER
115V



2*4 PVC BOX



15A 3 PIN PLUG
115V



½ COMPRESSION GLAND
PVC



GREY ELECTRICAL
TAPE



Wiring a Plug

To wire up a plug, you will need the following:

A set of wire cutters and, optionally wire strippers

An insulated electrical screwdriver, Phillips head, or flat

You should be aware that when you are replacing an existing plug (perhaps because it has been damaged) the colours of the wires in a mains lead may not correspond with the coloured markings identifying the terminals in the plug. Assuming that you have a modern cable with harmonised colours (Brown, Blue and Green and Yellow cores) you should proceed as follows:

Wiring a Plug

Warning: It sounds stupid, but people are really killed whilst trying to rewire a plug or change a fuse while it still plugged into the mains! You **MUST** disconnect the plug before working on it, and **NEVER** plug it back in until the case is sealed.

1. Unscrew the retaining screw so that you can open the plug.
2. Take the top and set it to one side, making sure that you do not lose the screw if it is removable on the plug you are using.

Wiring a Plug

3. If the plug has a screw-fitted cable clamp, unscrew it and set the screw(s) aside for later use.

Tip: If the clamp has two screws, remove one completely and leave the other connected but screw it almost to the end so that it can be rotated out of the way. This will both reduce the risk of losing screws and speed up the job – simply rotate back and fit the second screw once the job is done ("How to wire a plug," 2024).

Wiring a Plug

4. Cut and strip the cores to the correct length. There should only be enough copper exposed to match the depth of the terminal, and there must be no cuts, nicks or damage to any of the insulation on any core – if this happens, cut the wire back and start again.

Wiring a Plug

5. Fit the prepared wires to the appropriate terminals, ensuring that the retaining screw locates directly onto the copper and not onto the insulation, and that there is no more than 1mm of exposed copper outside the terminal:

- The wire which is coloured GREEN-AND-YELLOW must be connected to the terminal in the plug which is marked by the letter E or by the safety earth symbol or coloured GREEN or GREEN and YELLOW ("How to wire a plug," 2024).

Wiring a Plug

- The wire which is coloured BLUE must be connected to the terminal in the plug which is marked with the letter N or coloured BLACK.
 - The wire which is coloured BROWN must be connected to the terminal in the plug which is marked with the letter L or coloured RED
- ("How to wire a plug," 2024).

Wiring a Plug

6. When wiring a UK 3-pin plug, you should always leave more slack in the earth wire than in the live and neutral. This will ensure that, in the case of accidental pulling force on the cable, the earth wire will be the last to disconnect.
7. Refit the cable clamp and screw it down tight
8. Refit the plug lid and screw it down tight

("How to wire a plug," 2024)

TYPE A



TYPE B



TYPE C

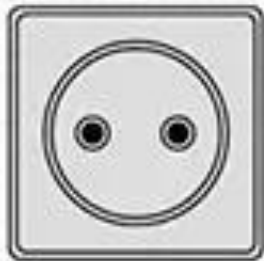

TYPE D



TYPE E

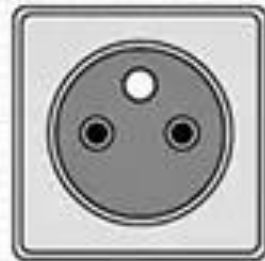

TYPE F

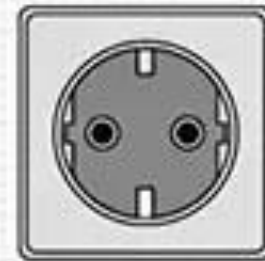

TYPE G



TYPE H



TYPE I



TYPE J

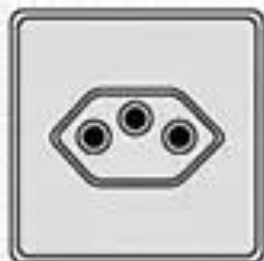

TYPE K



TYPE L

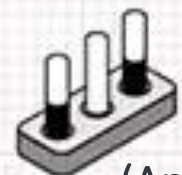
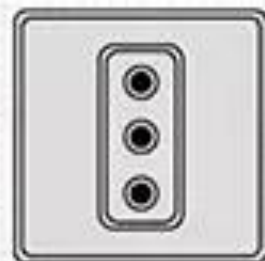

TYPE M

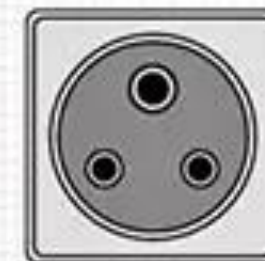

TYPE N

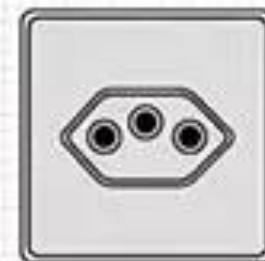

Type A



Type B



Type C



Type D



Type E



Type F



Type G



Type H



Type I



Type J



Type K



Type L



Type M



(Blogger, 2016)

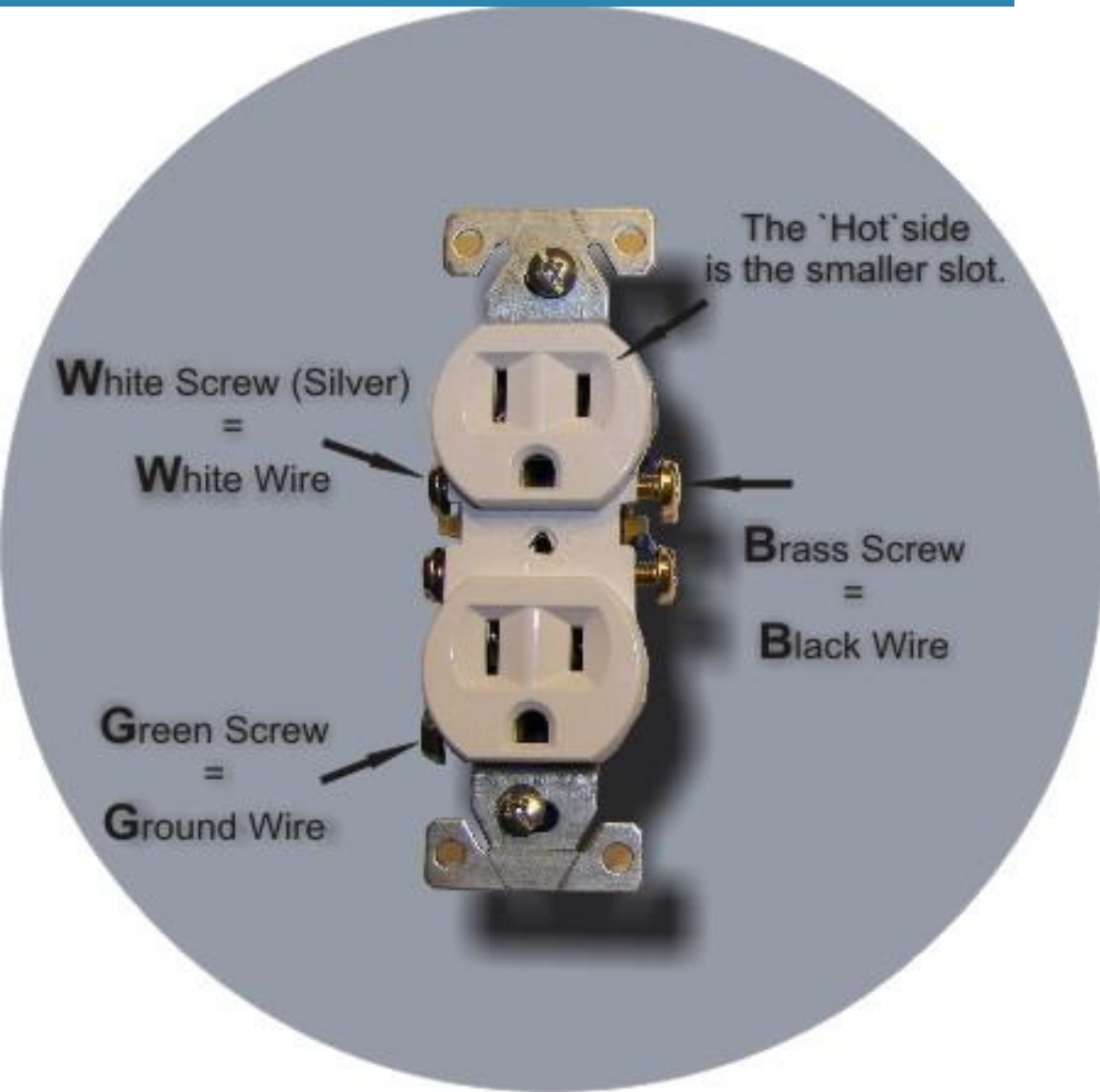

What is a receptacle outlet

A receptacle outlet is a device with protected current-carrying contacts intended to be connected to the fixed wiring of the installation and intended to receive a plug (Kristyn, 2024).

Receptacle Outlets Connection

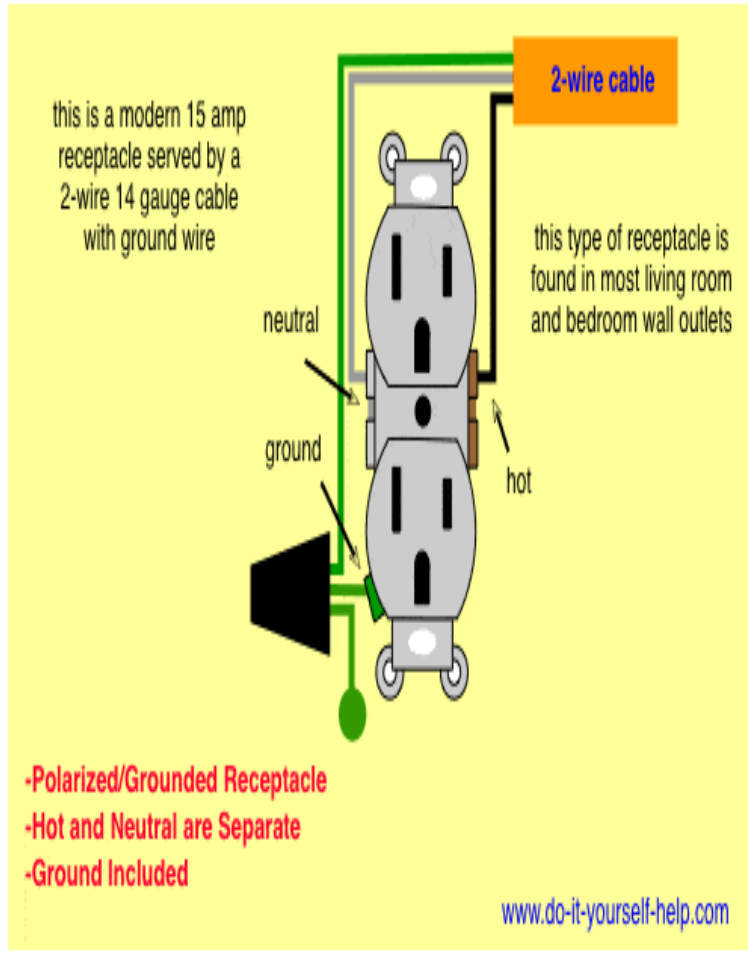

Parts of a 120 Volt AC Outlet

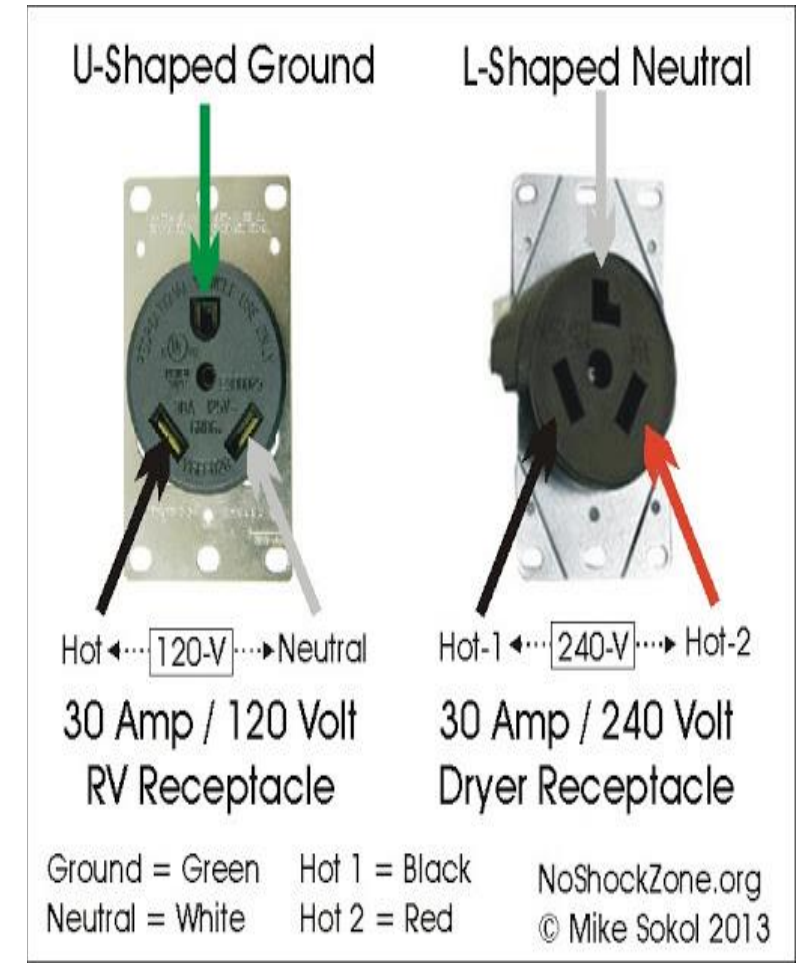
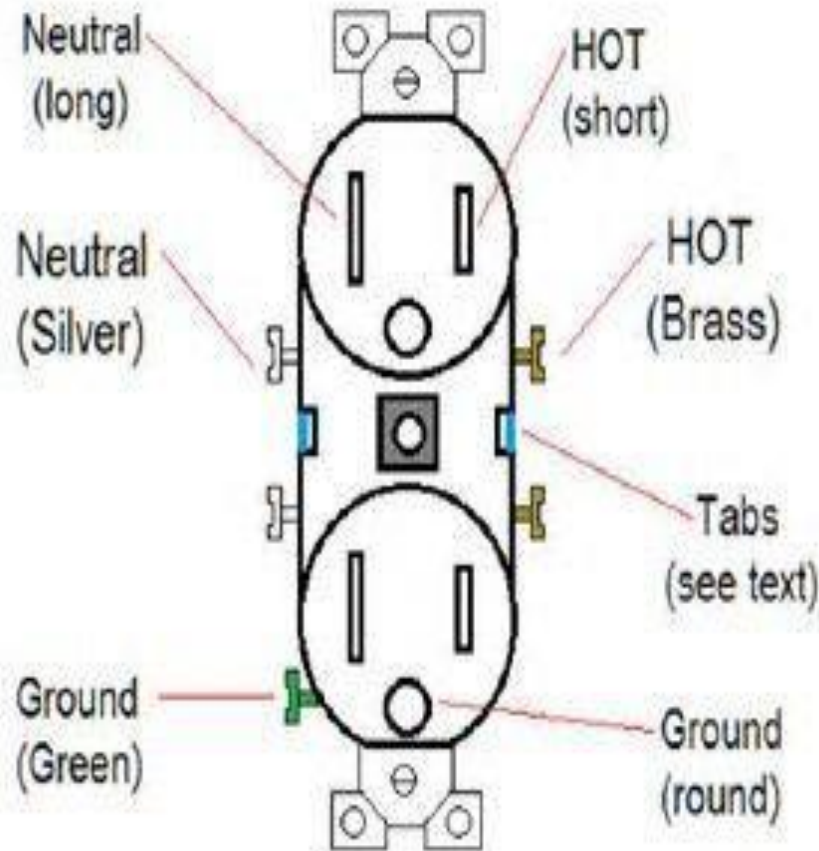

("Switched wall outlet wiring diagrams- do-it-yourself-help.com," n.d.)

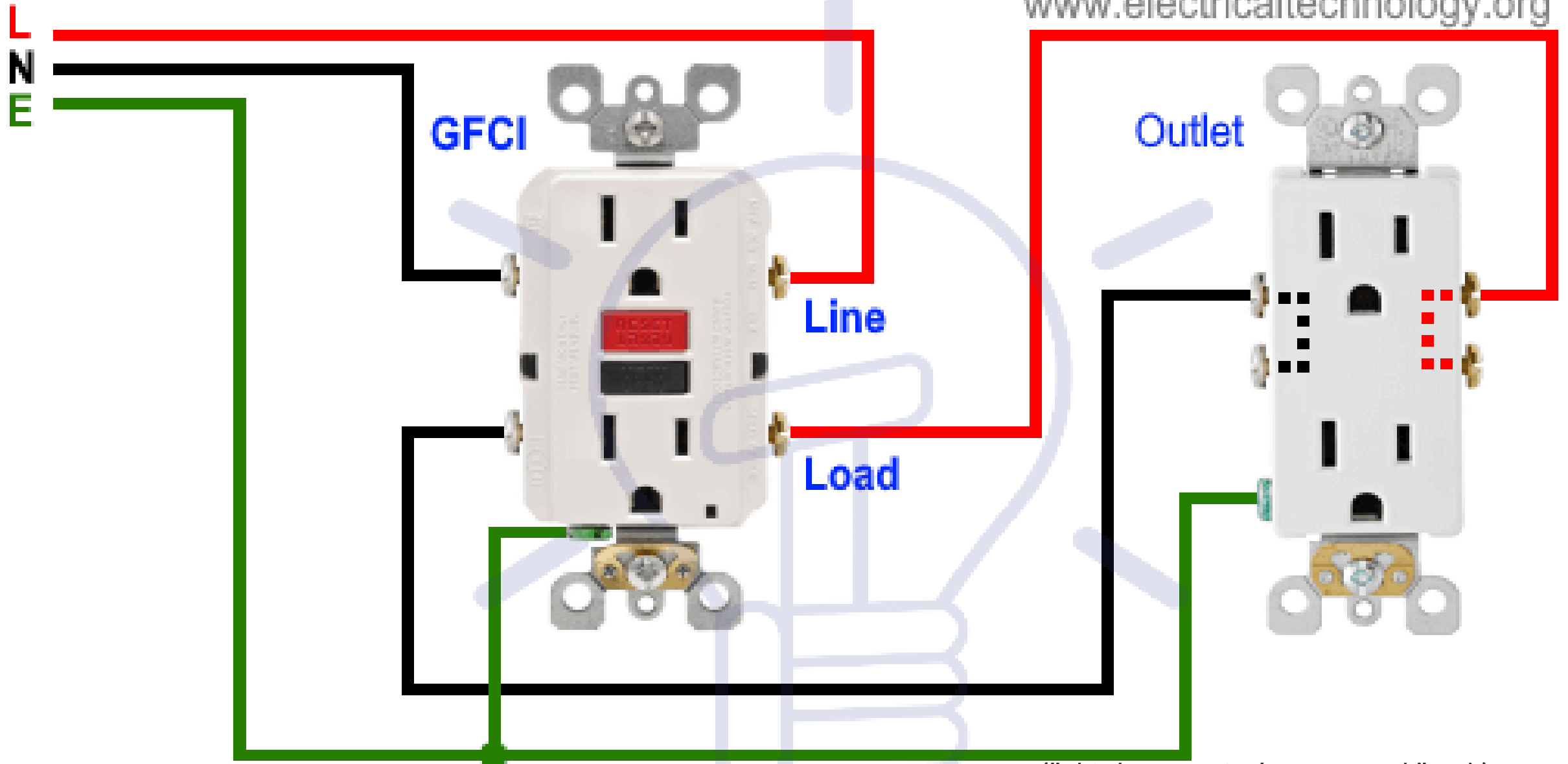

("This browser isn't supported," n.d.)

Outlet Connected to the Load Terminals are GFCI Protected

GFCI Outlet Wiring

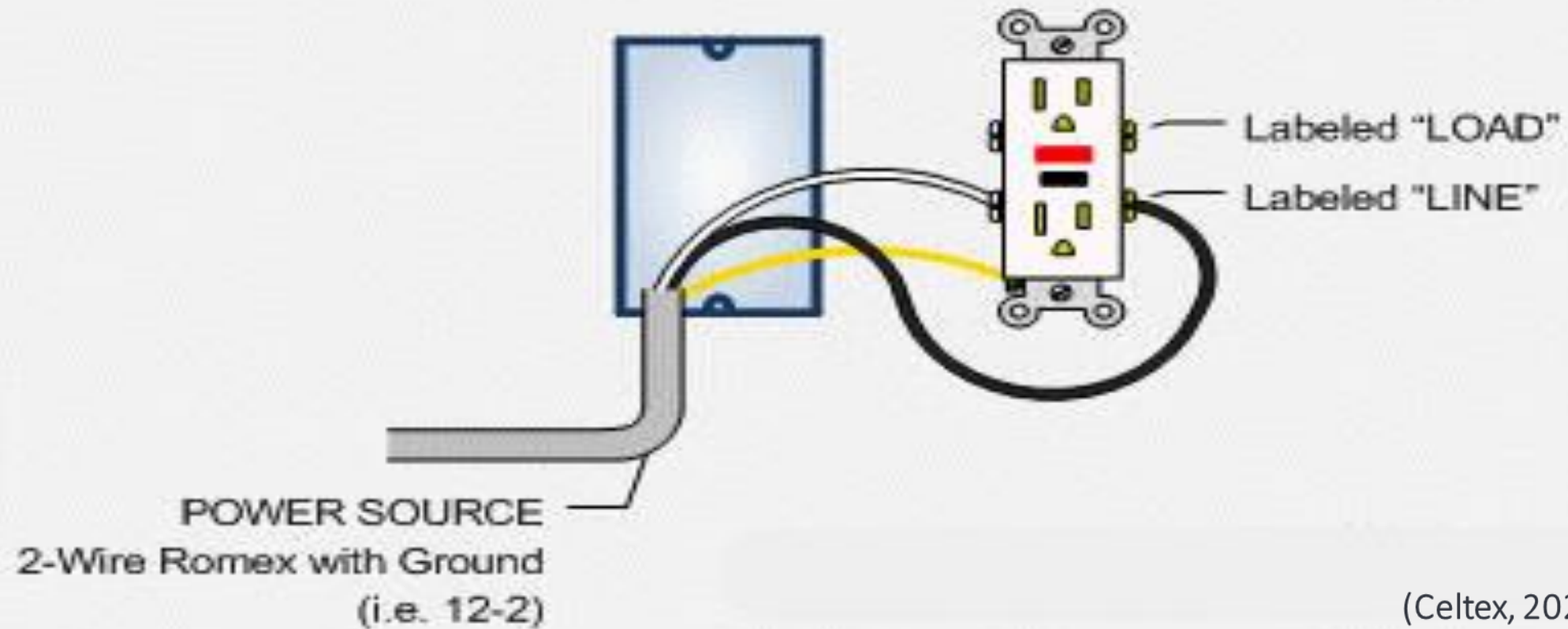

(Celtex, 2024)



(Kilnfrog, 2017)



(DIY Home Center, n.d.)





(DIY Home Center, n.d.)



50amp 240volt receptacle

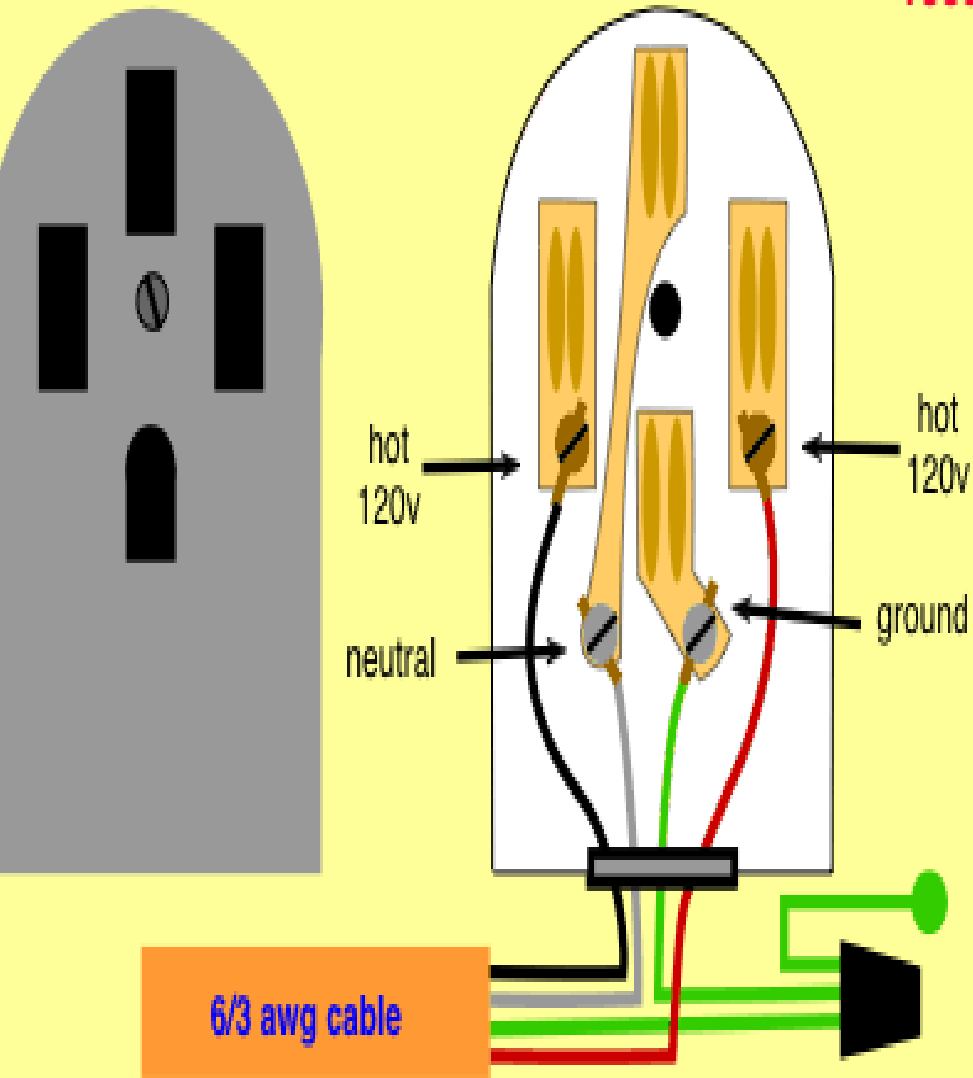

("Switched wall outlet wiring diagrams- do-it-yourself-help.com," n.d.)
www.do-it-yourself-help.com

50amp 240volt circuit

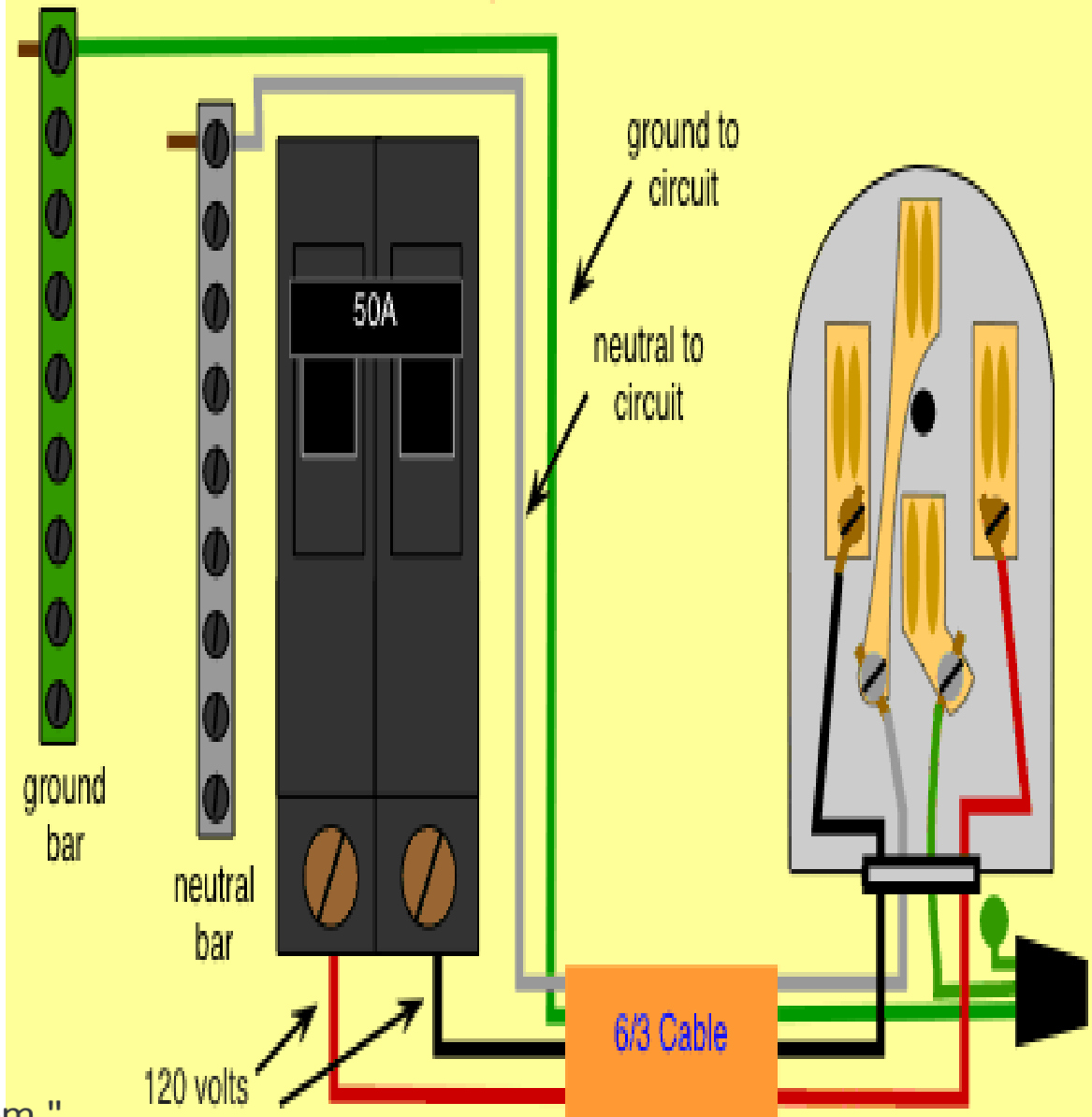

www.do-it-yourself-help.com

References

- Apfen. (2024, October 11). Navigating the world of power plug standards. *Apphone*. <https://www.szapphone.com/blog/navigating-the-world-of-power-plug-standards/>
- Blogger. (2016, September 10). Electrical plug & socket connector types. *electronics*. <https://atvelectronic.blogspot.com/2016/09/electrical-plug-socket-connector-types.html>
- Celtex. (2024, November 30). *How a GFCI works – Your guide to GFCI's | Celtex automation*. Celtex Electric & Automation. <https://celtex.ca/how-a-gfci-works-your-guide-to-gfcis/>
- DIY Home Center. (n.d.). *Leviton 50 amps 125/250 V duplex Black outlet 14-50R 1 pk*. Retrieved April 13, 2026, from <https://diyhomecenter.net/p/flush-mount-shallow-single-outlet-black-078477695302>
- How to wire a plug*. (2024, February 1). Ace Energy. <https://www.aceenergy.co.uk/news/how-to-wire-a-plug/>
- Kilnfrog. (2017, October 8). *The confusion about 120v outlets*. Kiln Frog. <https://kilnfrog.com/blogs/frogblog/the-confusion-about-120v-outlets?srsId=AfmBOoqzj-pXNjs-sBGaQ96J6QYaOy-koH0v-a8f5nUNUcVLLZO1DhJs>
- Kristyn. (2024, August 13). Types of outlets. *Lex Air Conditioning, Heating, Plumbing, Electrical*. <https://www.lexairconditioning.com/blog/2024/08/types-of-outlets/>
- Switched wall outlet wiring diagrams- do-it-yourself-help.com*. (n.d.). DIY Home Improvement Project Guides - Do-It-Yourself-Help.com. https://www.do-it-yourself-help.com/switched-outlet-wiring-diagrams#google_vignette
- This browser isn't supported*. (n.d.). Facebook. Retrieved April 13, 2026, from <https://www.facebook.com/electricaltechnology.info/posts/wiring-a-gfci-outlet-tutorial-httpswwwelectricaltechnologyorg202003wire-gfci-out/558730051438807/>
- Vandervort, D. (2024, December 12). *How electrical receptacles work*. HomeTips. <https://www.hometips.com/how-it-works/wiring-electrical-outlets.html>

Assignment Questions

1. State what is a plug.
2. List the local Trinidad and Tobago colour code for wiring a plug.
3. Draw a plug and name the correct parts of the plug.
4. State the different amperage of plugs.
5. State what is a receptacle outlet.
6. List the local Trinidad and Tobago colour code and cable size for wiring a receptacle outlet.
7. Draw and name the parts of the receptacle outlets.
8. Give the amperage of three[3] types of outlets.
9. What is the meaning of GFCI.
10. List the components needed to wire a receptacle outlet on a wall.

THANK YOU

ANY QUESTIONS?

